

DT3

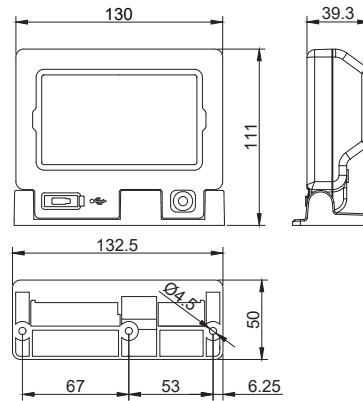

TFT Display with Free-Stop Hinge



Key Features

- Free-Stop Display Angle Adjustment
- Auto Screen Rotation
- Integrated TFT Resistive Touch Panel
- USB Data Backup Support
- Optional Replaceable Li-Ion Battery

Applications

- Remote Axle Scale Monitoring
- Remote Control of Axle Scale Indicator
- Truck Scale Data Sharing
- Wireless Axle Scale Auxiliary Display

Specifications

Case Material	ABS
Display	4.3" IPS TFT LCD
Input Method	Resistive touch panel
Wireless	ZigBee
Frequency Band	ISM 2.4 GHz
Wireless Protocol	IEEE 802.15.4
Wireless Range	Typical Range: 30 m (max. 300 m)
USB Interface	USB Type-A (for data backup via USB memory)
Power	12-24 VDC, 1.5 W
AC Adapter	12 VDC, 2 A SMPS (for system power and battery charging)
Temperature	-20 to 60 °C
Humidity	85% RH (Non-condensing)
Weight	270 g

Options

OP-01 RS-232

OP-21 Replaceable Li-ion battery