

DTI3

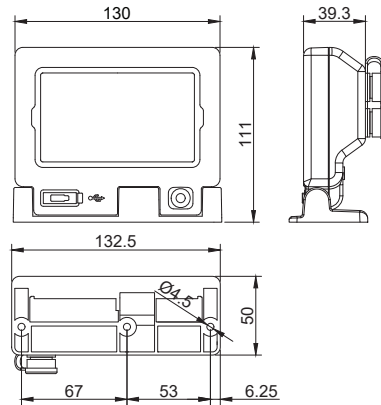

TFT Indicator with Free-Stop Hinge



Key Features

- Free-Stop Display Angle Adjustment
- Auto Screen Rotation
- Integrated TFT Resistive Touch Panel
- USB Data Backup Support
- Optional Replaceable Li-Ion Battery

Applications

- Mobile Cart and Workstation Weighing
- Forklift Scale Weighing System
- Medical Bed Scale System
- Process Monitoring and Quality Control

Specifications

Case Material	ABS
Display	4.3" IPS TFT LCD
Touchscreen	Resistive touch panel
ADC Resolution	24-bit
Output Data Rate	Up to 50 Hz
Excitation	3 VDC, up to 8 × 350 Ω load cell
Sensitivity	0.2 uV/d
Input Range	0–39 mV (±19.5 mV)
USB Interface	USB Type-A (for data backup via USB memory)
Power	12–24 VDC, 1.5 W
AC Adapter	12 VDC, 2 A SMPS (for system power and battery charging)
Temperature / Humidity	-20 to 60 °C / 85% RH (Non-condensing)
Weight	270 g

Options

OP-01 RS-232

OP-21 Replaceable Li-ion battery