

RWN Series



Wireless Axle Weighing



Key Features

- Replaceable Battery
- Up to 44 Days Operation
- Integrated Ramp (RWN-5)
- Supports Up to 8 Scales
- Works with RWN-1 Indicator

Applications

- Overload Monitoring
- Vehicle Entry Control
- Alternative to Truck Scales
- Weighing Station Setup

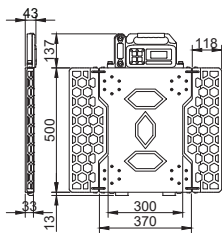

RWN-5

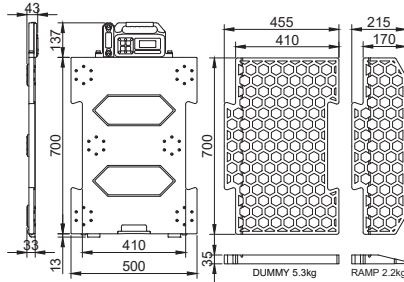

RWN-7

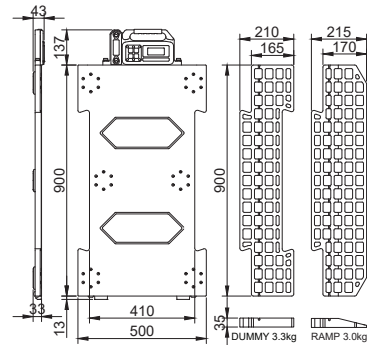

RWN-9

Specifications

Model	RWN-5		RWN-7			RWN-9		
Max Capacity (kg)	3000	5000	10000	15000	20000	10000	15000	20000
Readability (kg)	1	2	10	10	20	10	10	20
Display	5-digit FSTN LCD (16 mm character height), LED backlight							
Input Method	4 tactile keys							
Case Material	Front case: Glass fiber-reinforced ABS (GF-ABS) / Body housing: Aluminum							
Ramp / Dummy	Polyurethane rubber							
Wireless	ZigBee (IEEE 802.15.4, typical range: 30 m (max. 300 m))							
Protection Rating	IP67							
Battery	Replaceable Li-ion battery, approx. 44 days (8 h/day, max. 350 h), charger included							
Charger Input	5 VDC, 1.5 A SMPS							
Temperature / Humidity	-20 to 60 °C / 85% RH (Non-condensing)							
Weight	15.6 kg		22.4 kg			27.0 kg		

Options

Dummy pad (for RWN-7 / RWN-9)